



↘

---

# Experiences in modeling PV plants for grid operators

What is next?

**ESTUDIOS**ELECTRICOS 

➤ Scope of services

**FIELD TESTING,  
MATHEMATICAL  
MODELING &  
COMMISSIONING**

**TRANSMISSION AND  
POWER PLANT  
SIMULATION STUDIES**

**R&D SIMULATION  
AND ANCILLARY  
SERVICES TOOLS**

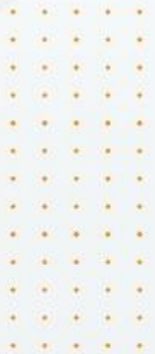

## ➤ Offices buildings and Projects

- **LOCATIONS**

Argentina, Chile, Colombia, Panama and United States.

- **WORLD WIDE PROJECTS**

We deployed our staff in strategic locations to achieve the best solution tailor made in each part of the region.



**STAFF: + 70**

**PROJECTS: + 3000**



# Contents

---

- Typical Acceptance Requirements and Tests
- Modelling According to Requirements
- Learned Lessons and Recommendations
- What is next?



---

# Typical Acceptance Requirements and Tests



# Typical Acceptance Requirements

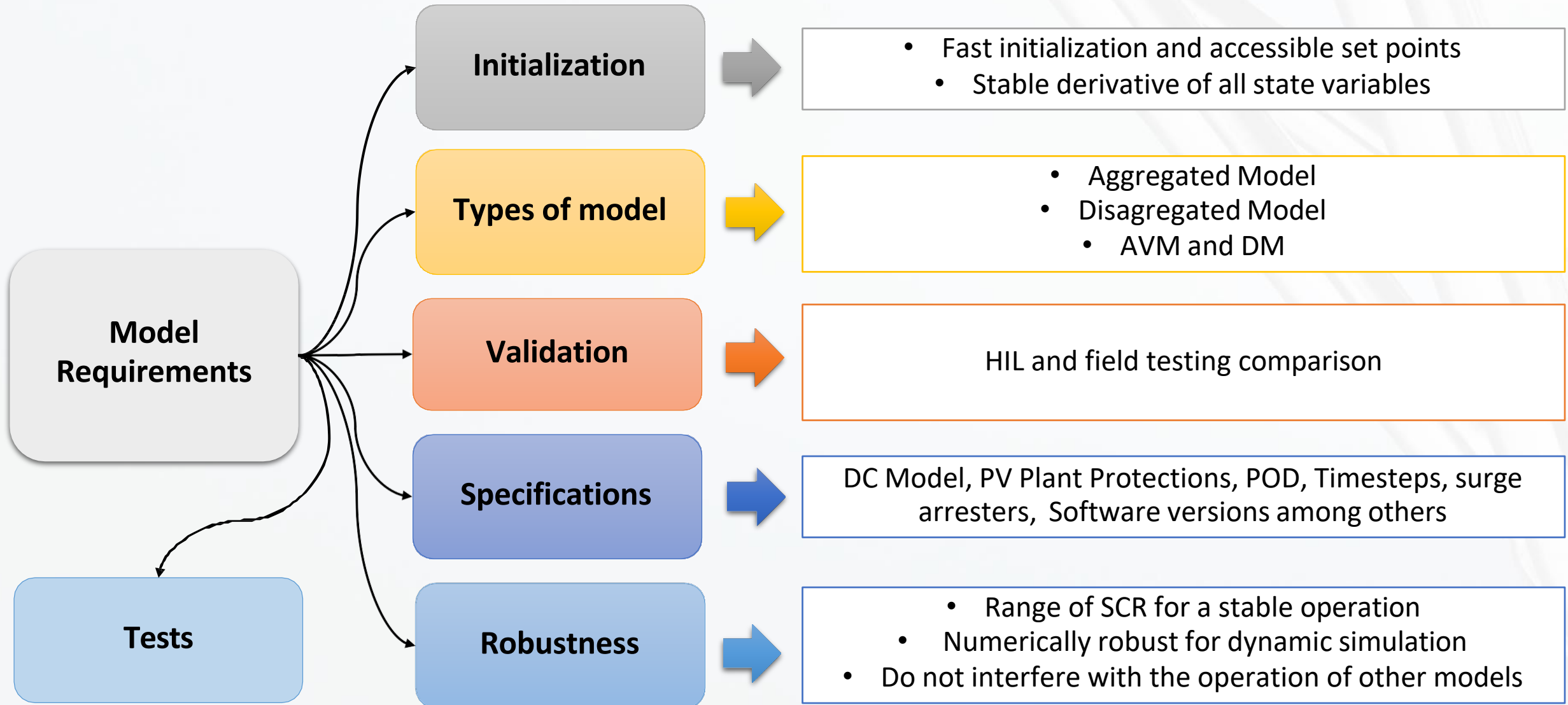

# Typical Tests

## Active Power Control

- DeadBand and Droop
- P control
- FRT

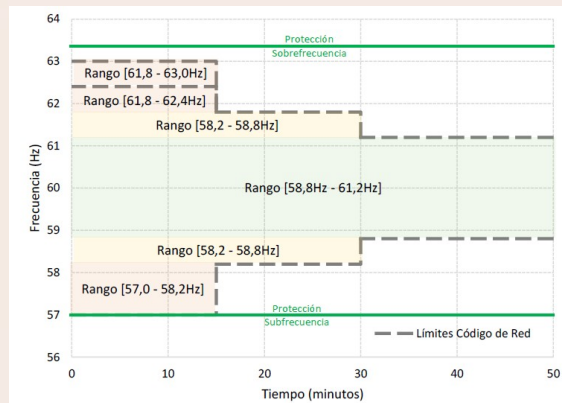

## Voltage Control

- Capability Curve at POI
- Q, PF and Voltage modes

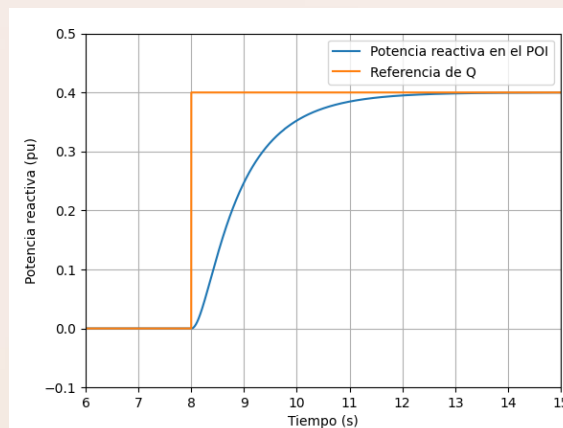

## Faults

- Passive and active voltage SAG.
- Balanced and unbalanced faults
- VRT
- P and Q priority

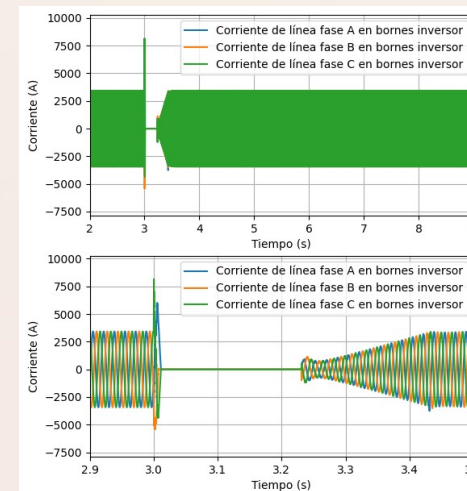

## Others

- Change of SCR
- Protections
- Additional functions:
  - POD
  - Inertia
- Stable conditions

Ref.: **AEMO**: Dynamic Model Acceptance Test Guideline, V2. November 2021.

# Modelling According to Requirements



# Modelling According to Requirements

## Internal Grid

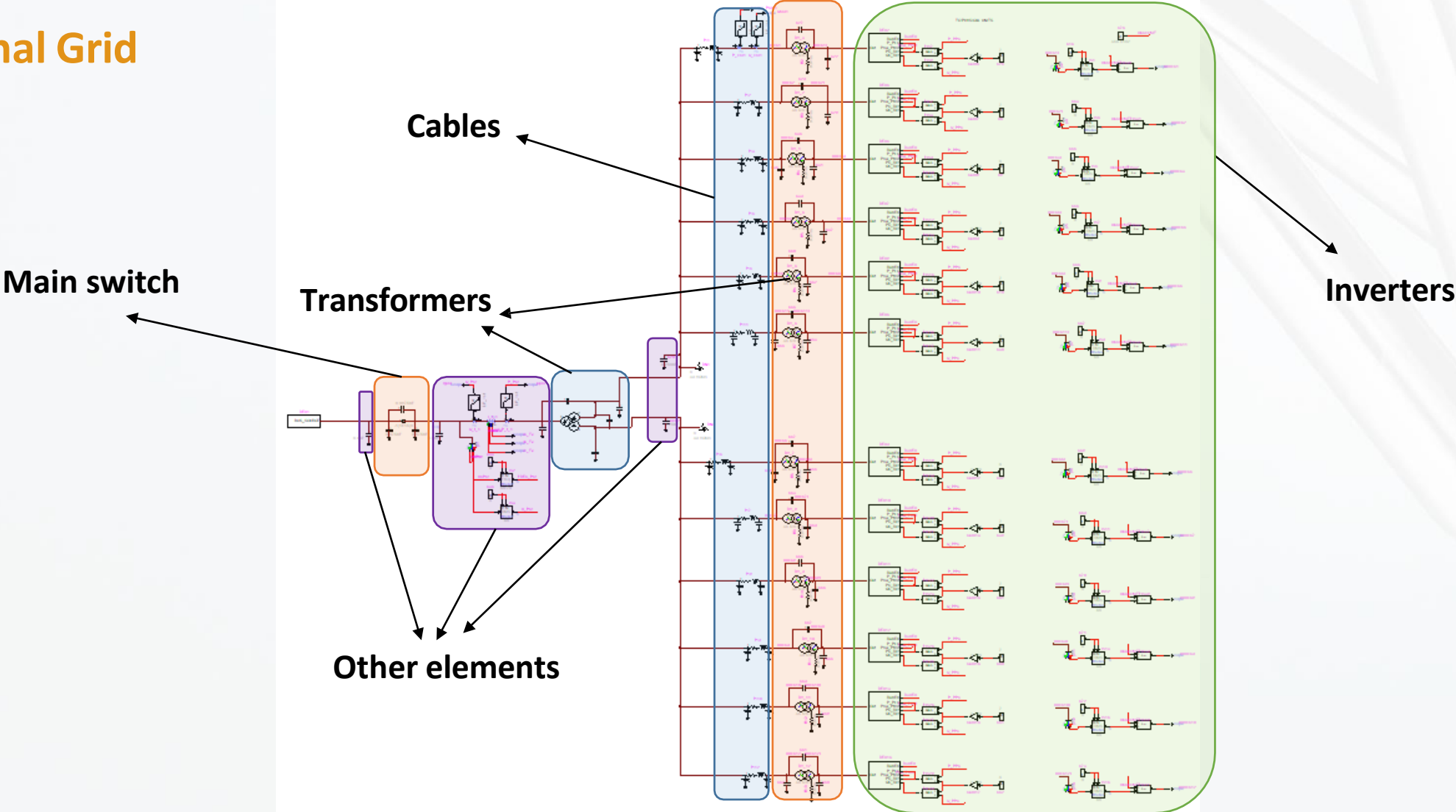

# Modelling According to Requirements

## Internal Network equivalent: Aggregated Model

Detailed

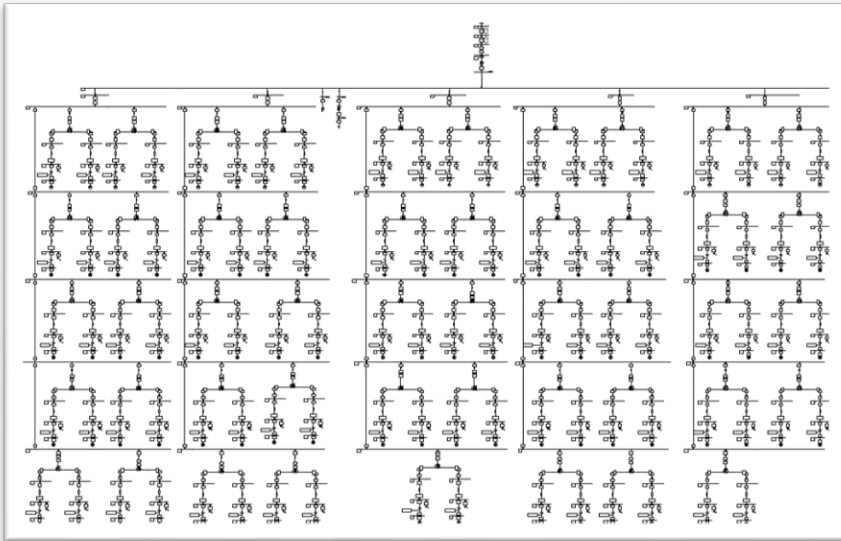

Aggregated

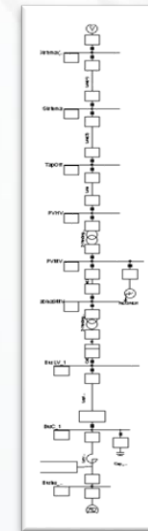

Impedance calculated from losses

$$R_{pu} = \frac{P_{Loss}}{3I^2 Z_{base}}$$

$$X_{pu} = \frac{Q_{tot\_Loss} - V_{pu}^2 B_{pu} S_{base}}{3I^2 Z_{base}}$$

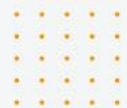

Ref.: Muljadi, E., et al. "Equivalencing the collector system of a large wind power plant." 2006 IEEE Power Engineering Society General Meeting. IEEE, 2006.

# Modelling According to Requirements

## Internal Grid

- ✓ Cables
- ✓ Transformers
- ✓ Others

\* The elements should be modelled according to the studied phenomenon

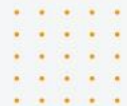
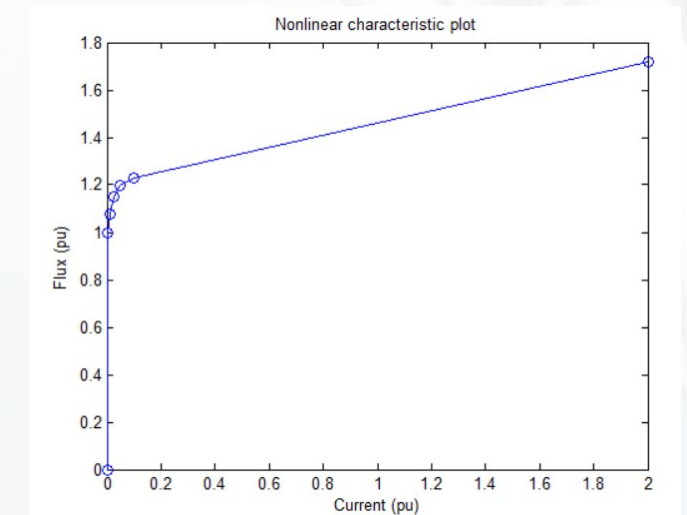
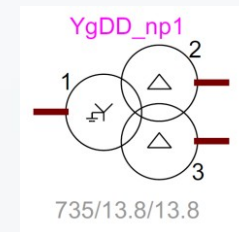
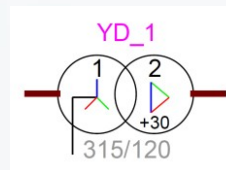
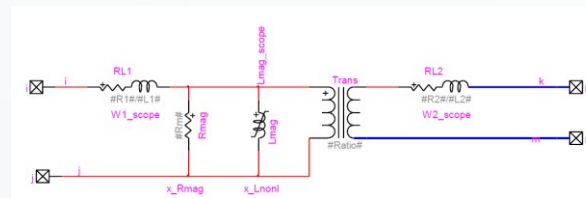
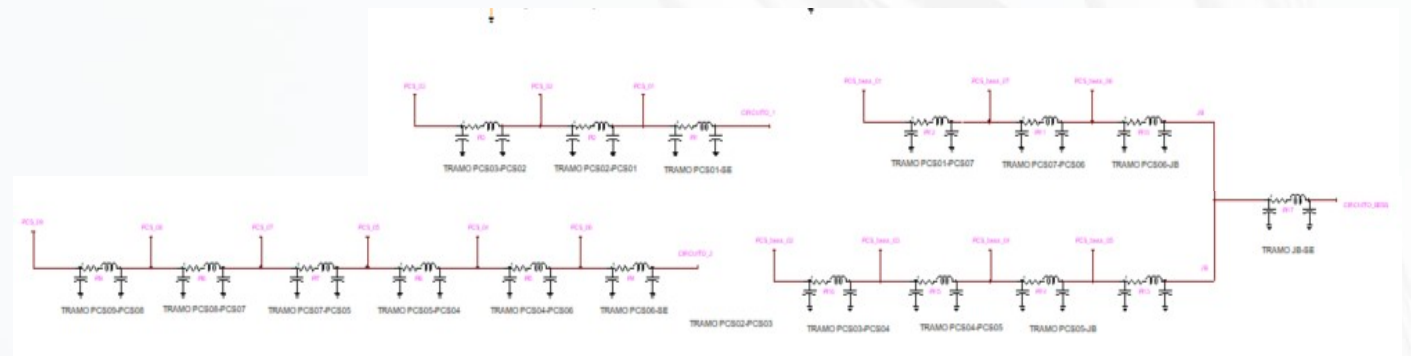

# Modelling According to Requirements

## Inverter and PPC

- **Static model:** Capability curve
- **Converter model:** AVM or DM
- **Filter LC or LCL**
- **Controls and protections**
  - **Phase Locked Loop (PLL)**
  - Current Loop  $I_d$  and  $I_q$
  - PWM
  - Fault mode
  - Momentary Cessation

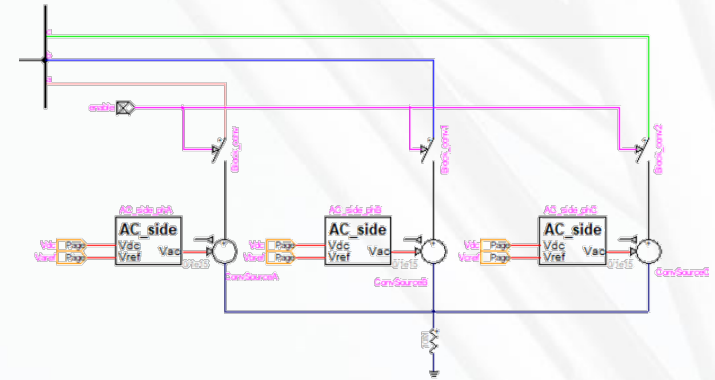
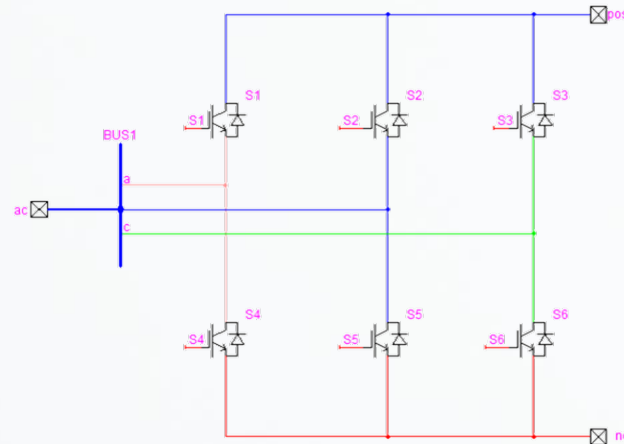

## DC Side

- **PV Cells:** Validation
- **MPPT**
- **DC Condenser**

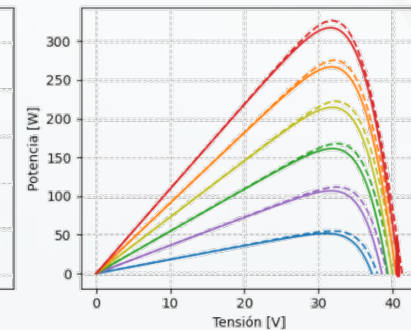
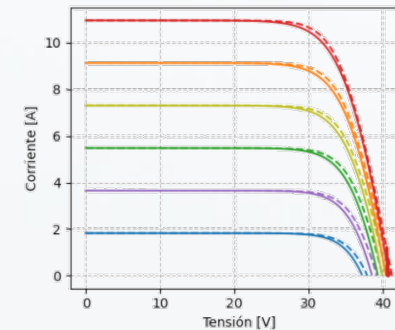
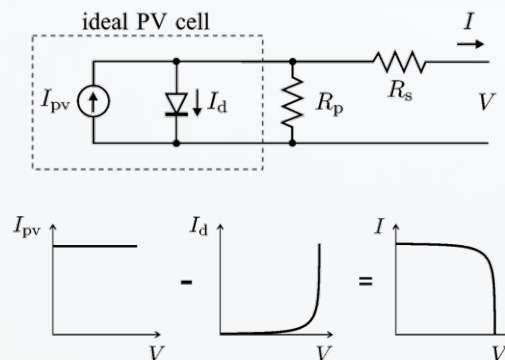
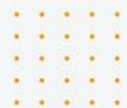

# Lessons Learned



# Lessons Learned

## Timestep and aliasing

The deterioration in the variable's waveforms due to the triangular wave deformation increases with the time step.

- The nature of EMT simulation requires fine tuning when choosing time step and plotting frequency range.
- As a standard solution for this problem, the **Nyquist frequency** determines the ideal relation between the variables and the sampling frequencies
- **AVM is suitable for larger time steps** ( $>5\mu\text{s}$  approx.)

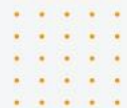
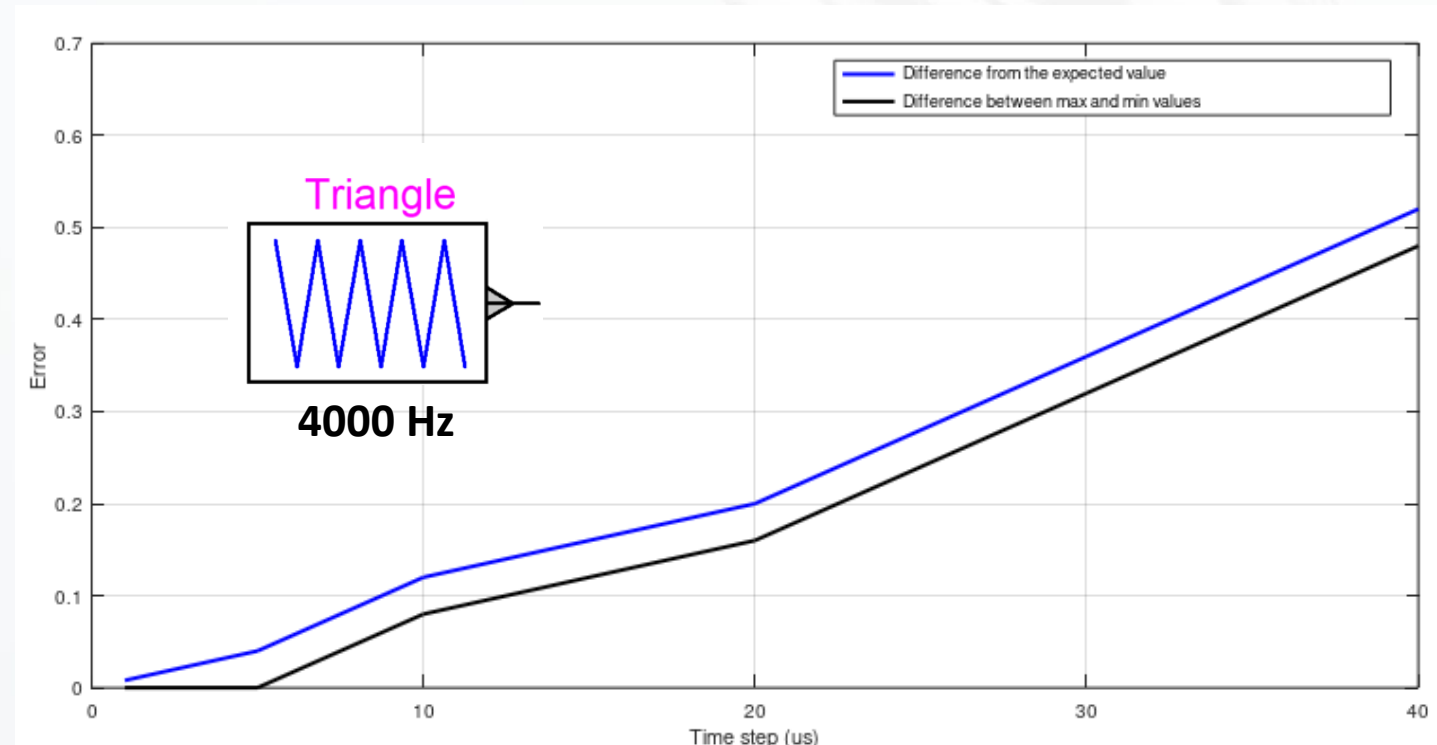

# Lessons Learned

## Electrical phenomena v/s control

Identify the nature of the studied phenomenon helps to understand the origin of the problems.

**Case Study: the IGBT opens during a 3 $\Phi$  fault due to overcurrent.**

- Slow current control
- Resonance with filter LC

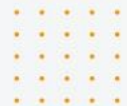
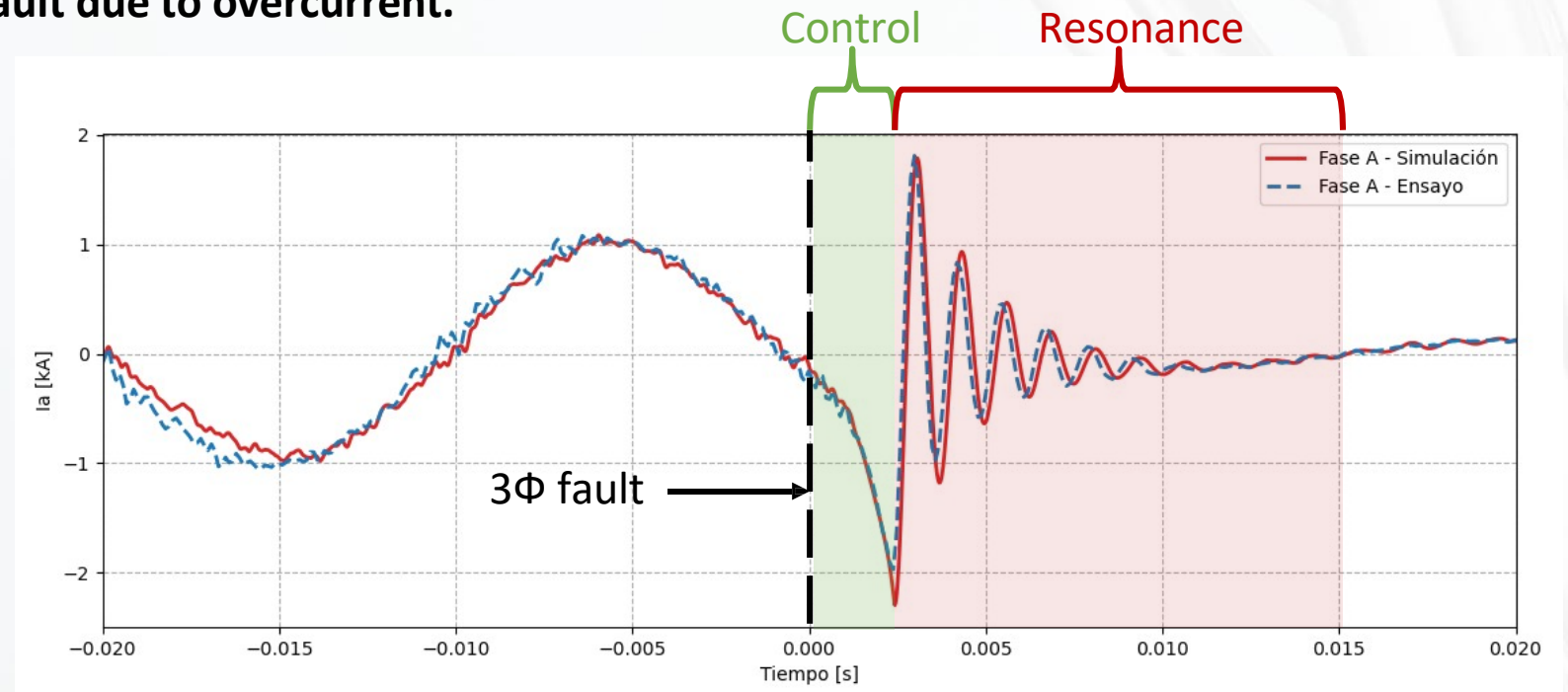

# Lessons Learned

## Short Circuit Ratio (SCR) Range

SCR operation range can be approximated from static model, RMS simulations, modal analysis and **EMT simulations**.

A low SCR ( $\approx \text{SCR} < 2$ ) can derive in:

- Unstable simulations, initialization problems, PLL loss of synchronism, Power and Voltage oscillations

Time domain

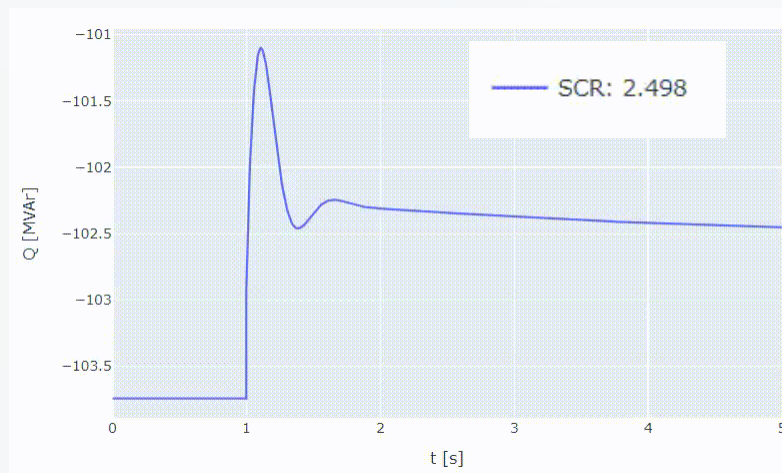

Modal Analysis

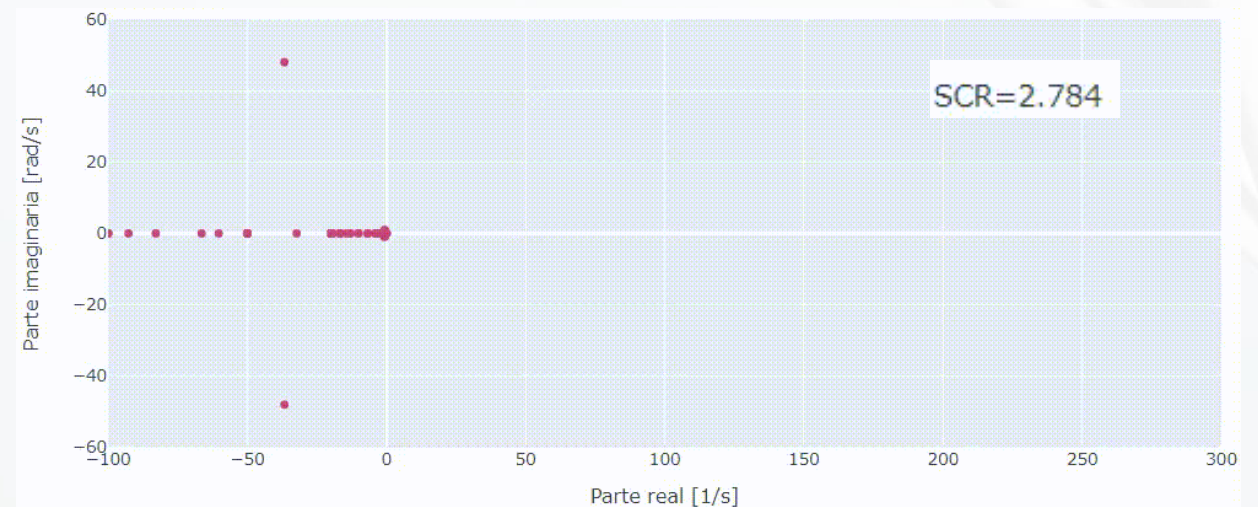

# Lessons Learned

---

- ✓ Manufacturer and field-testing **collaboration**
- ✓ Each System has its **own technical and modelling requirements**
- ✓ Operator Requirements → Modelling accordingly → Information needed
- ✓ **Timesteps** lower than the smallest time constants is recommended
- ✓ **Monitoring** of main electrical and control variables
- ✓ Check fault control algorithms (**variable freezing**) during faults
- ✓ Understanding **different time scales** of the controls helps to identify problems

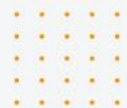

---

# What is next?



# What is Next?

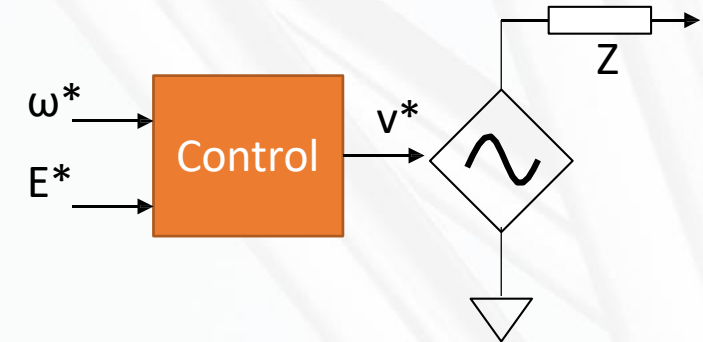
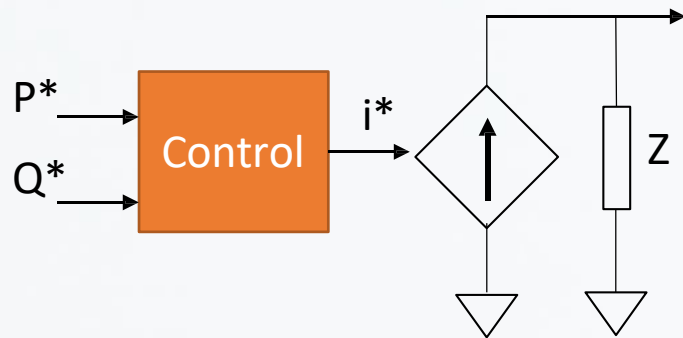

PLL to measure  $\theta$

Requires a minimum system strength

Controlled Current

Closed Voltage loop

Fast response

Grid Support

Calculates and sets  $\theta$

Island mode operation

Controlled voltage



# What is Next?

## Grid Forming generic model

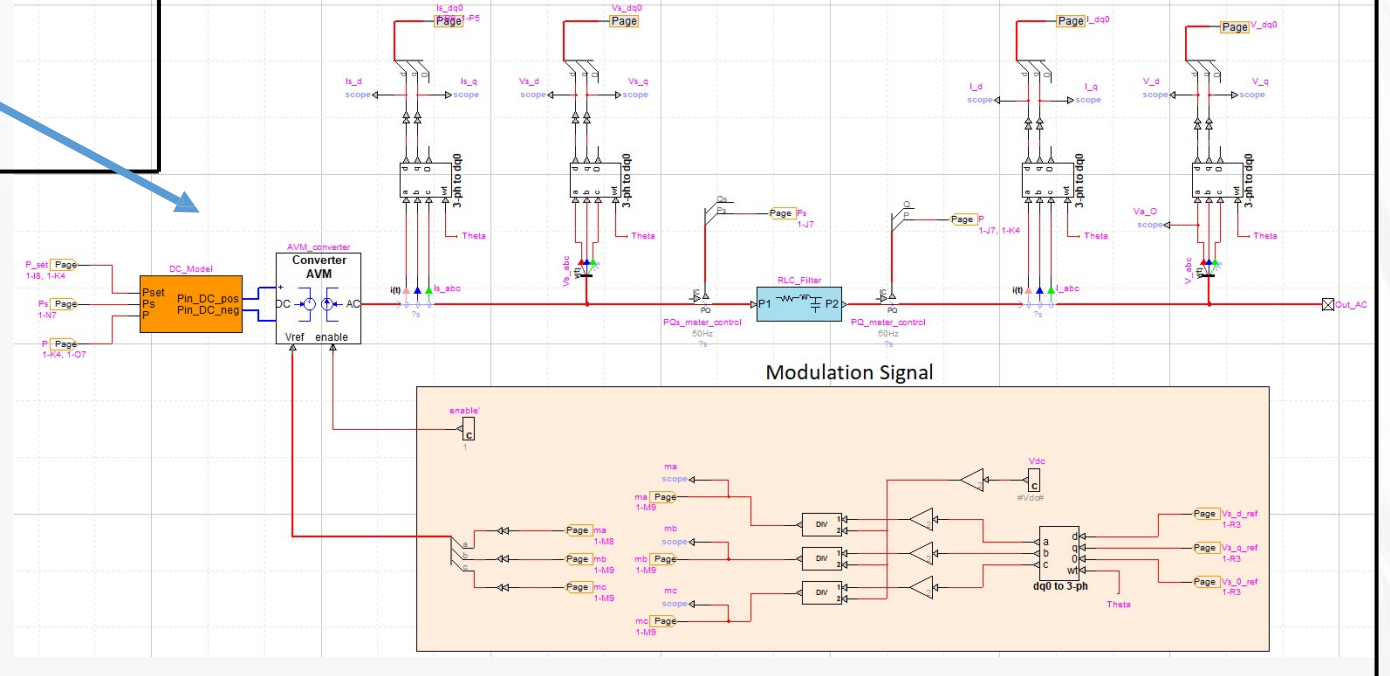
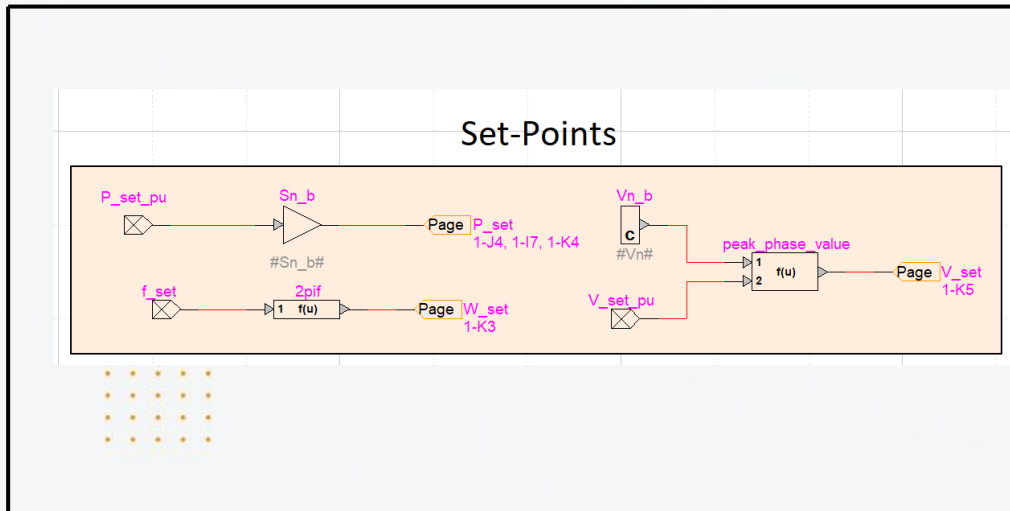
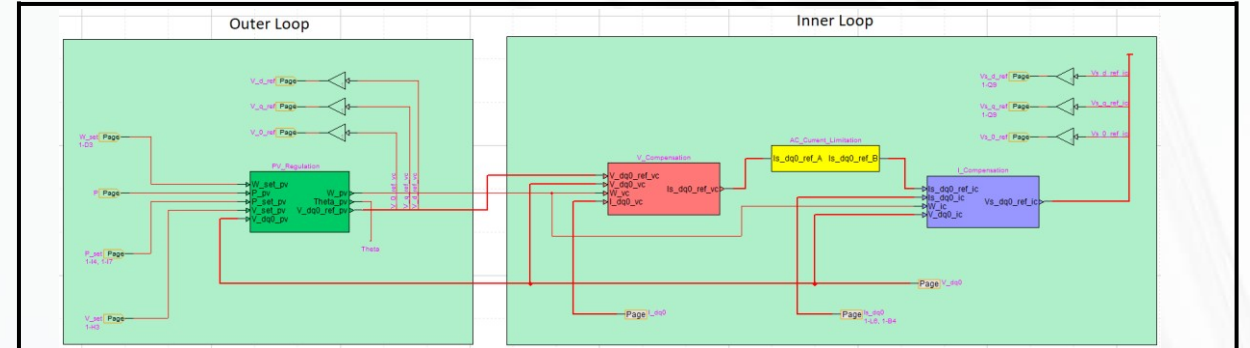
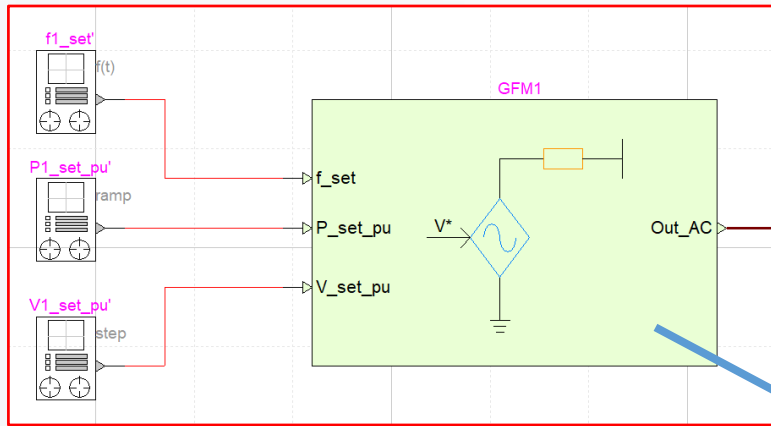

# What is Next?

## Current Limitation

- Primary resources.
  - DC current < 1,2 p.u.
- Inverter
  - AC current < 1,2 p.u.
- **Margin stability is reduced** considering current limits
- The design of a robust and effective control strategy is still an **open research problem.**

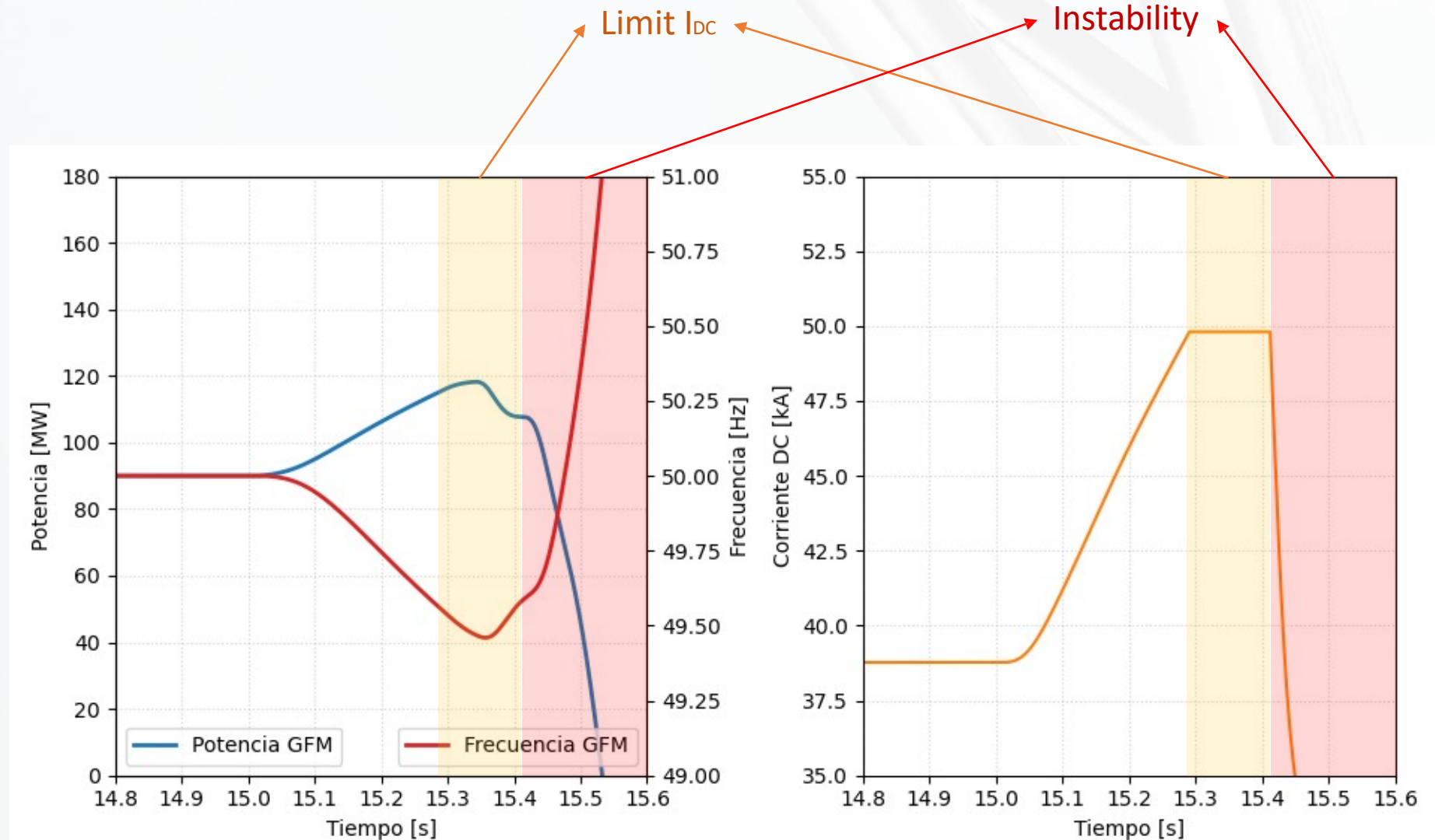
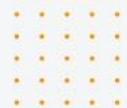

# What is Next?

## P Compensation

$$\Delta P^* = \begin{cases} 0 & \text{si } \|I_{s\_dq0}\| \leq I_{AC\_P} \\ \sigma * (\|I_{s\_dq0}\| - I_{AC\_P}) & \text{si } \|I_{s\_dq0}\| > I_{AC\_P} \end{cases} ; \quad \sigma = \frac{K\_dP}{I\_b\_LV}$$

## Results:

- It is possible to **stabilize the system** by pushing the current injection away from the limits.
- It changes the final operation point.

Ref.:  
Tayyebi, A. Frequency stability of synchronous machines and grid-forming power converters. *IEEE Journal of Emerging and Selected Topics in Power Electronics*, 8(2), 1004-1018.

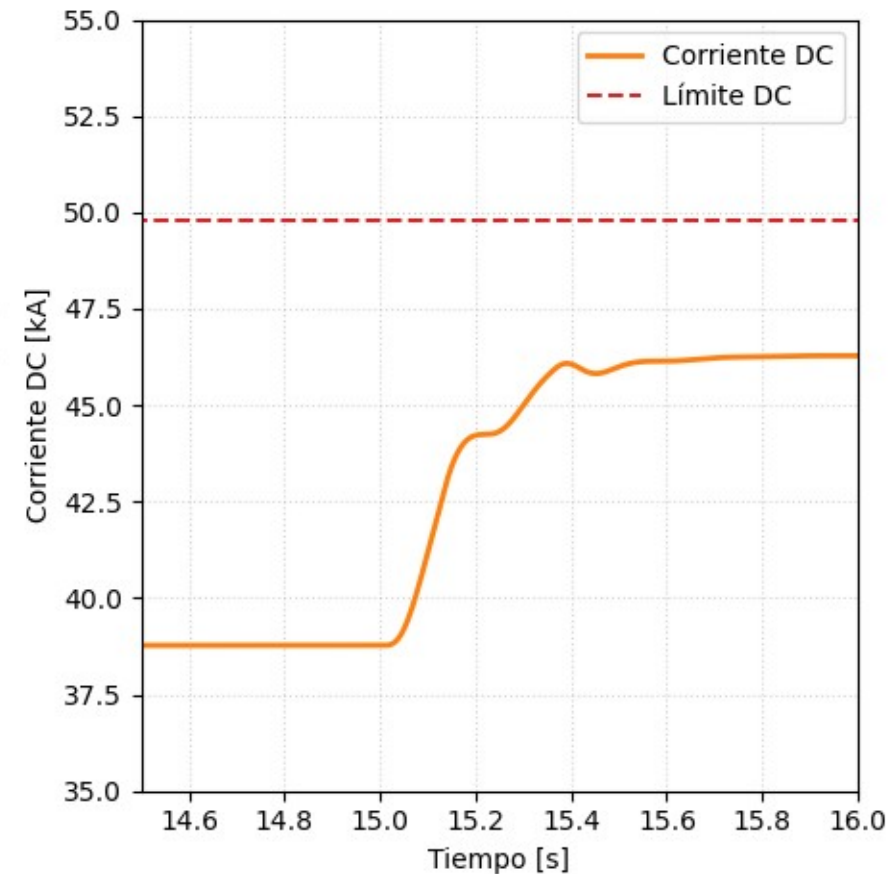
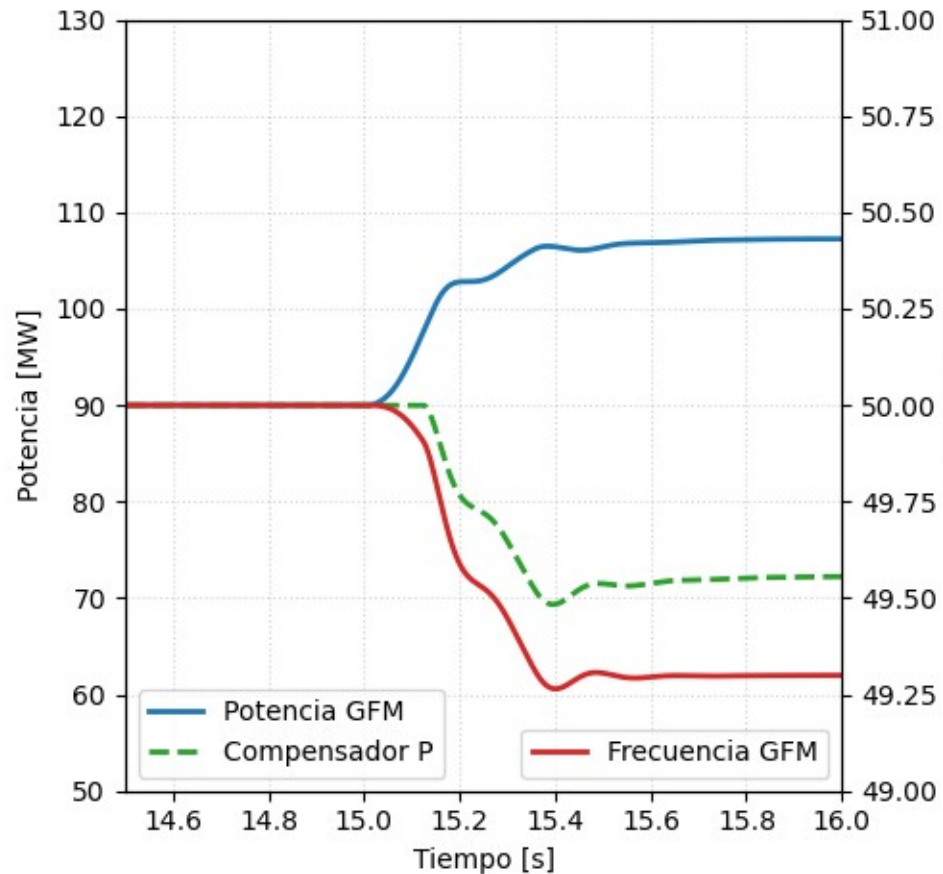

# What is Next?

---

- ✓ Further study of the **dynamics of GFM** is required under **severe faults**
- ✓ **New regulation/requirements** for GFM should be promoted
- ✓ **Different acceptance criteria** than GFL considering:
  - ✓ Grid strength and island operation capability
  - ✓ Current limitations
  - ✓ Coupling of Active and Reactive Power
  - ✓ Behavior under severe faults

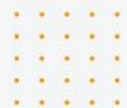



---

# Thanks

Q&A